



TRANSIT CONNECT TRADE PACKAGES

VEHICLE SHELVING SYSTEMS



FLOOR LAYOUT PLANS

120.5" WHEELBASE

INSIDEROOF HEIGHT
REGULAR ROOF: 46"

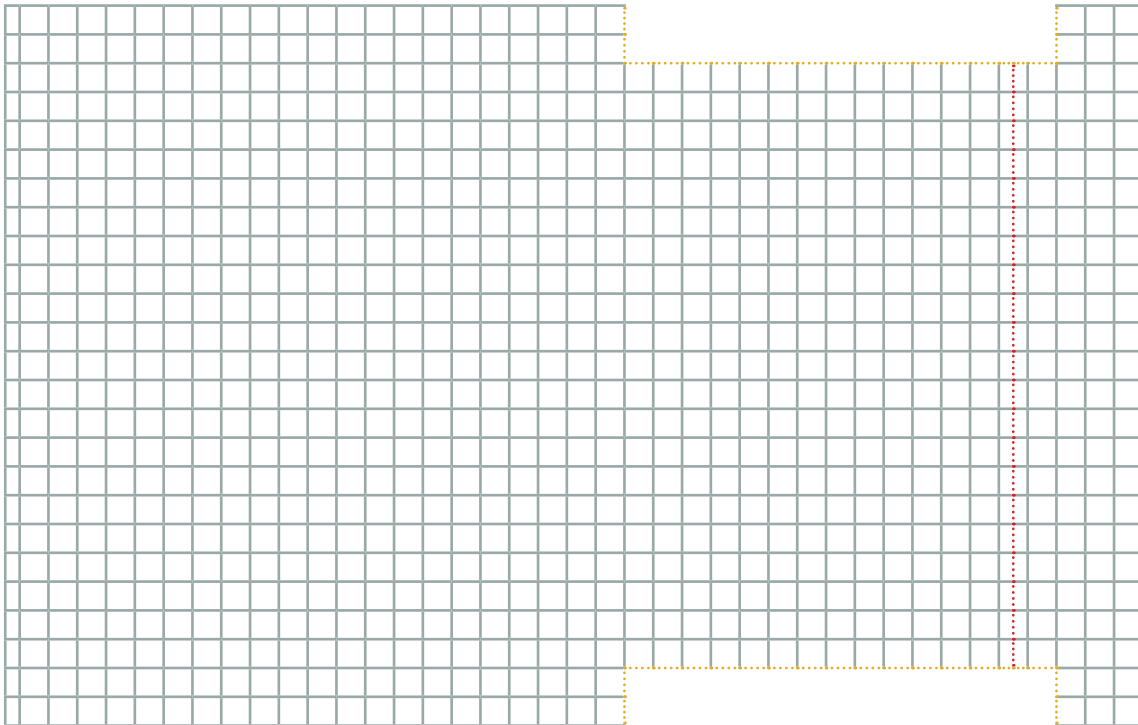
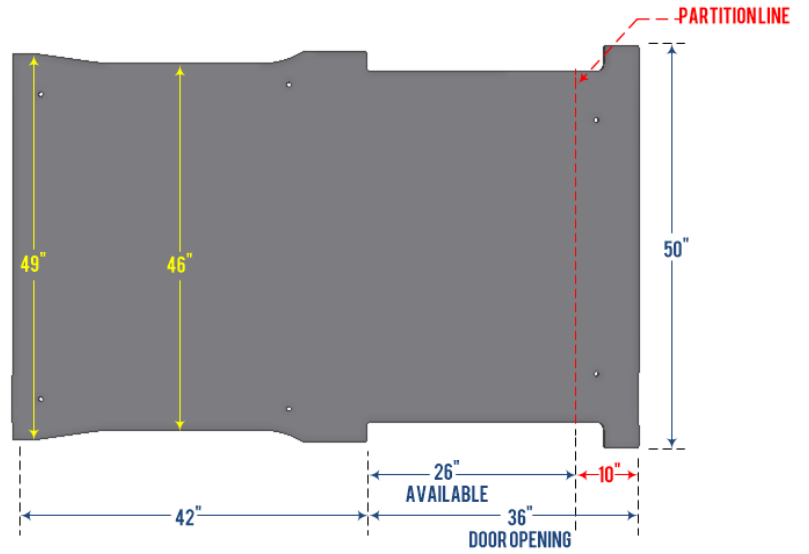

LEGEND:

□ 1 INCH (APPROX.)

□ 2 INCHES (APPROX.)

⋮ PARTITION

⋮ WHEELHOUSE

FORD TRANSIT CONNECT

TRANSIT CONNECT 120.5" WHEELBASE REGULAR ROOF	4
PARTITIONS	10
ACCESSORIES	11

LEGEND:



APPROXIMATE WEIGHT (LBS)



APPROXIMATE INSTALL TIME (HRS)



SPEED SHIP AVAILABILITY

TRADE PACKAGES

TRANSIT CONNECT 120.5" WHEELBASE REGULAR ROOF



60-FC21-C1

CONTRACTOR PACKAGE

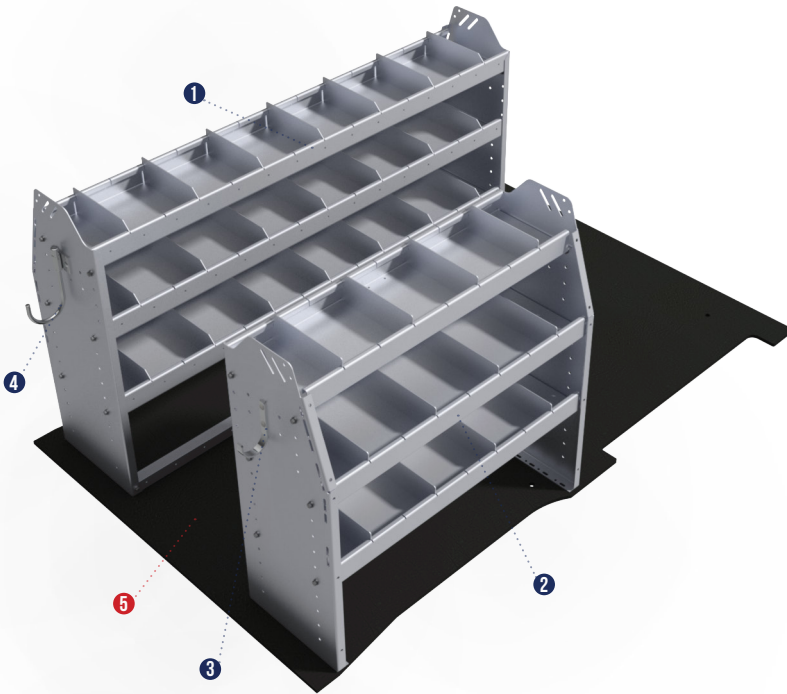

#	QTY	PART NUMBER	DESCRIPTION
1	1	21-6336-3	PROFILED BACK SHELF UNIT 60"WIDE X 13.5"DEEP X 36"HIGH WITH 3 SHELVES
2	1	21-3336-3	PROFILED BACK SHELF UNIT 36"WIDE X 13.5"DEEP X 36"HIGH WITH 3 SHELVES
3	1	30-HK-FMD	FIXED MEDIUM HOOK (3" OPENING)
4	1	30-HK-SMD	SWIVEL MEDIUM HOOK (4" OPENING)
OPTIONS			
5	1	31-FC20-XX	--OPTIONAL-- SEE VEHICLE SPECIFIC RIGID FLOORING SYSTEMS SECTION



100



4.1



YES

60-FC21-E1

ELECTRICAL PACKAGE

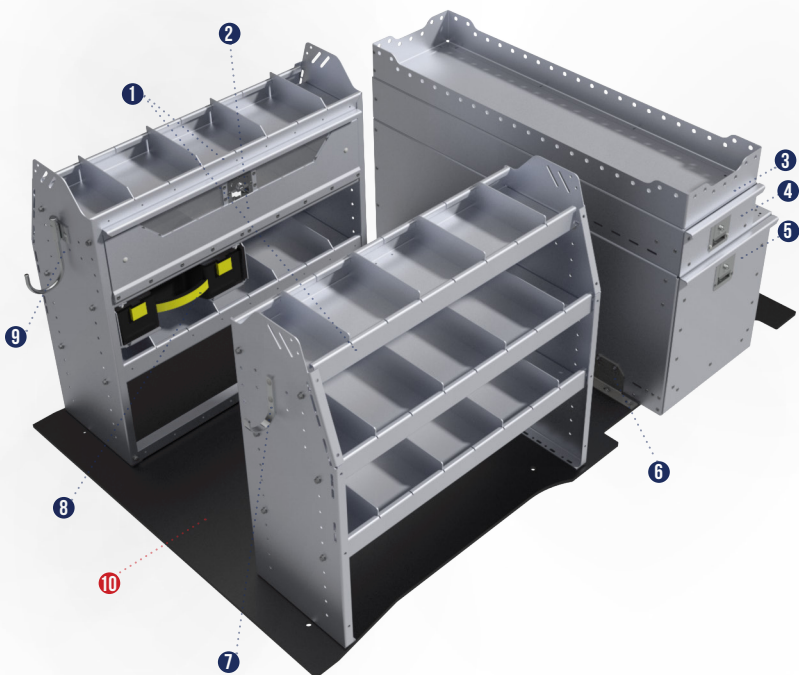

#	QTY	PART NUMBER	DESCRIPTION
1	2	21-3336-3	PROFILED BACK SHELF UNIT 36"WIDE X 13.5"DEEP X 36"HIGH WITH 3 SHELVES
2	1	DO-136	LOCKING DOOR FOR 36"WIDE SHELVING UNIT
3	1	30-TE-34	TOP EDGE FOR DRAWER CABINET 13.5"WIDE X 48"DEEP
4	1	11-3406-0	DRAWER CABINET 13.5"WIDE X 48"DEEP X 6"HIGH
5	1	11-8420-0	DRAWER CABINET 18"WIDE X 48"DEEP X 20"HIGH
6	1	30-FH-8	18"WIDE DRAWER BOLT DOWN BRACKET
7	1	30-HK-FMD	FIXED MEDIUM HOOK (3" OPENING)
8	1	30-CCH-SK	UNDER SHELF CARRY CASE HOLDER W/CASE
9	1	30-HK-SMD	SWIVEL MEDIUM HOOK (4" OPENING)
OPTIONS			
10	1	31-FC20-XX	--OPTIONAL-- SEE VEHICLE SPECIFIC RIGID FLOORING SYSTEMS SECTION



212



5.8



YES

TRADE PACKAGES

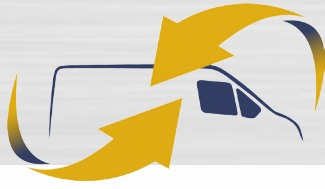

TRANSIT CONNECT 120.5" WHEELBASE REGULAR ROOF

60-FC21-S1

SERVICE PACKAGE

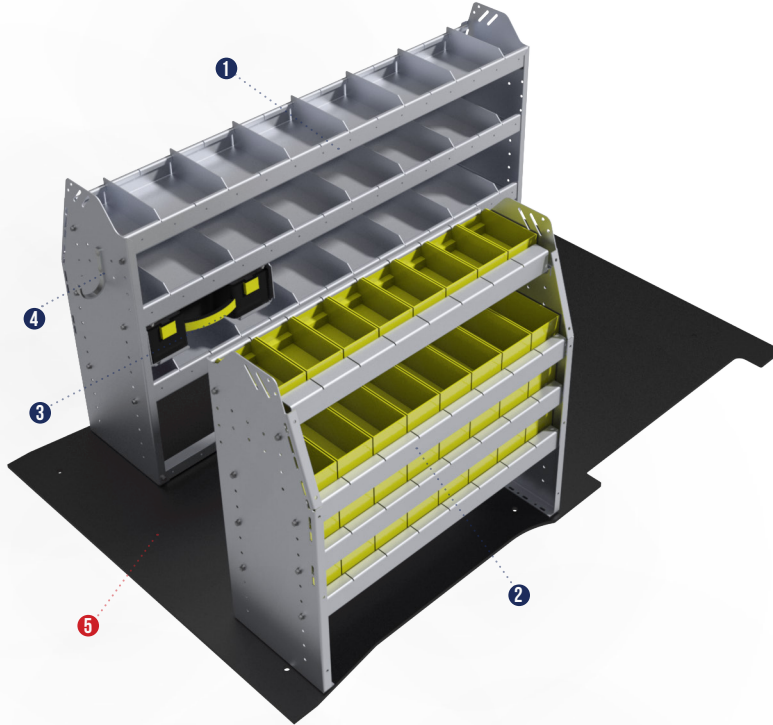

#	QTY	PART NUMBER	DESCRIPTION
1	1	21-6336-3	PROFILED BACK SHELF UNIT 60"WIDE X 13.5"DEEP X 36"HIGH WITH 3 SHELVES
2	1	23-3336-4	PROFILED BACK BIN SHELF UNIT 34.5"WIDE X 13.5"DEEP X 36"HIGH WITH 4 SHELVES
3	1	30-CCH-SK	UNDER SHELF CARRY CASE HOLDER W/CASE
4	1	30-HK-FMD	FIXED MEDIUM HOOK (3" OPENING)
OPTIONS			
5	1	31-FC20-XX	--OPTIONAL-- SEE VEHICLE SPECIFIC RIGID FLOORING SYSTEMS SECTION



124



4.1



YES

60-FC21-W1

WORKSTATION PACKAGE

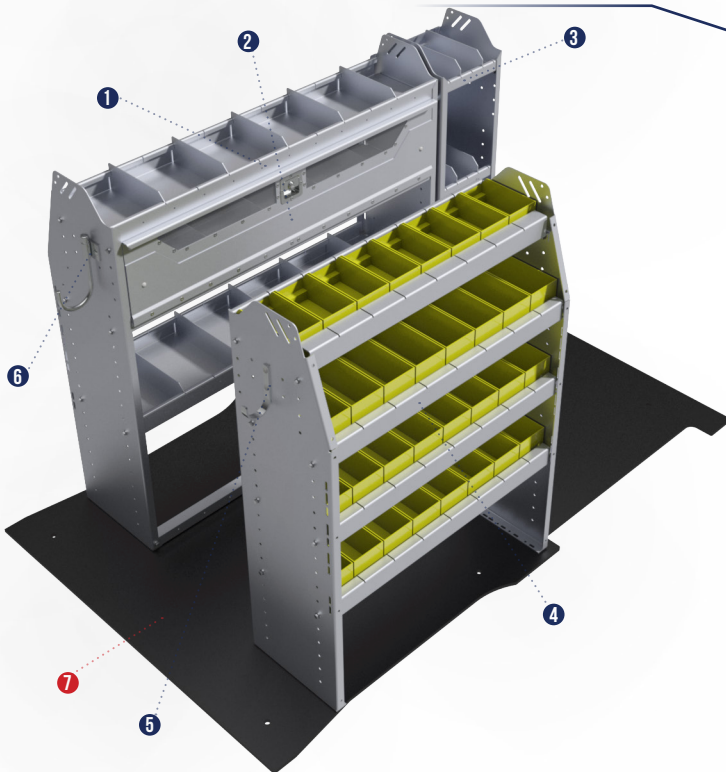

#	QTY	PART NUMBER	DESCRIPTION
1	1	21-4348-3	PROFILED BACK SHELF UNIT 48"WIDE X 13.5"DEEP X 48"HIGH WITH 3 SHELVES
2	1	DO-148	LOCKING DOOR FOR 48"WIDE SHELVING UNIT
3	1	29-1348-4	PROFILED BACK BOOKSHELF, 11"WIDE X 13.5"DEEP X 48"HIGH WITH 4 SHELVES
4	1	23-3348-4	PROFILED BACK BIN SHELF UNIT 34.5"WIDE X 13.5"DEEP X 48"HIGH WITH 4 SHELVES
5	1	30-HK-FMD	FIXED MEDIUM HOOK (3" OPENING)
6	1	30-HK-SMD	SWIVEL MEDIUM HOOK (4" OPENING)
OPTIONS			
7	1	31-FC20-XX	--OPTIONAL-- SEE VEHICLE SPECIFIC RIGID FLOORING SYSTEMS SECTION



154



5.1



YES

TRADE PACKAGES

TRANSIT CONNECT 120.5" WHEELBASE REGULAR ROOF



60-FC21-H1

HVAC PACKAGE

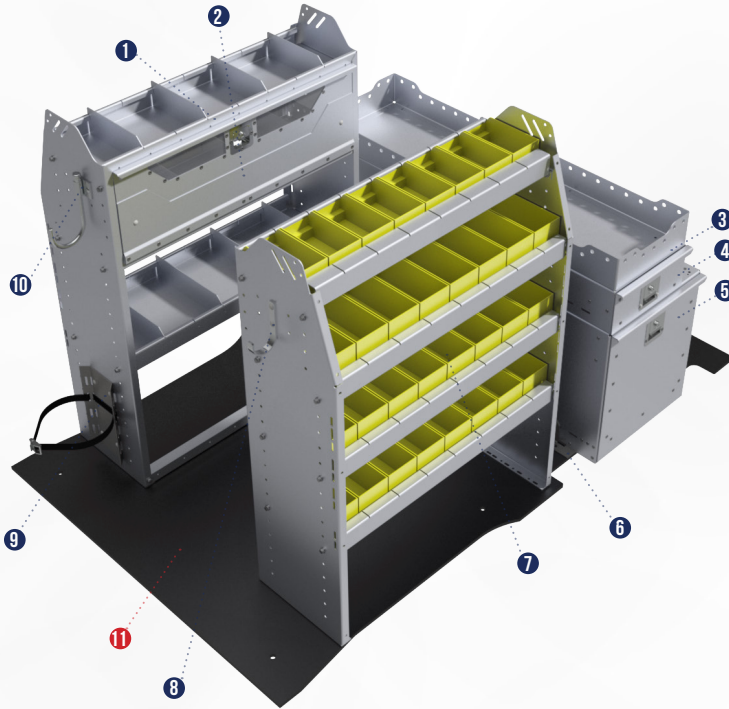

#	QTY	PART NUMBER	DESCRIPTION
1	1	21-3348-3	PROFILED BACK SHELF UNIT 36"WIDE X 13.5"DEEP X 48"HIGH WITH 3 SHELVES
2	1	DO-136	LOCKING DOOR FOR 36"WIDE SHELVING UNIT
3	1	30-TE-34	TOP EDGE FOR DRAWER CABINET 13.5"WIDE X 48"DEEP
4	1	11-3406-0	DRAWER CABINET 13.5"WIDE X 48"DEEP X 6"HIGH
5	1	11-8420-0	DRAWER CABINET 18"WIDE X 48"DEEP X 20"HIGH
6	1	30-FH-8	18"WIDE DRAWER BOLT DOWN BRACKET
7	1	23-3348-4	PROFILED BACK BIN SHELF UNIT 34.5"WIDE X 13.5"DEEP X 48"HIGH WITH 4 SHELVES
8	1	30-HK-FMD	FIXED MEDIUM HOOK (3" OPENING)
9	1	30-BH-SM	SMALL BOTTLE HOLDER
10	1	30-HK-SMD	SWIVEL MEDIUM HOOK (4" OPENING)
OPTIONS			
11	1	31-FC20-XX	--OPTIONAL-- SEE VEHICLE SPECIFIC RIGID FLOORING SYSTEMS SECTION



229



6.5



YES

60-FC21-P1

PLUMBING PACKAGE

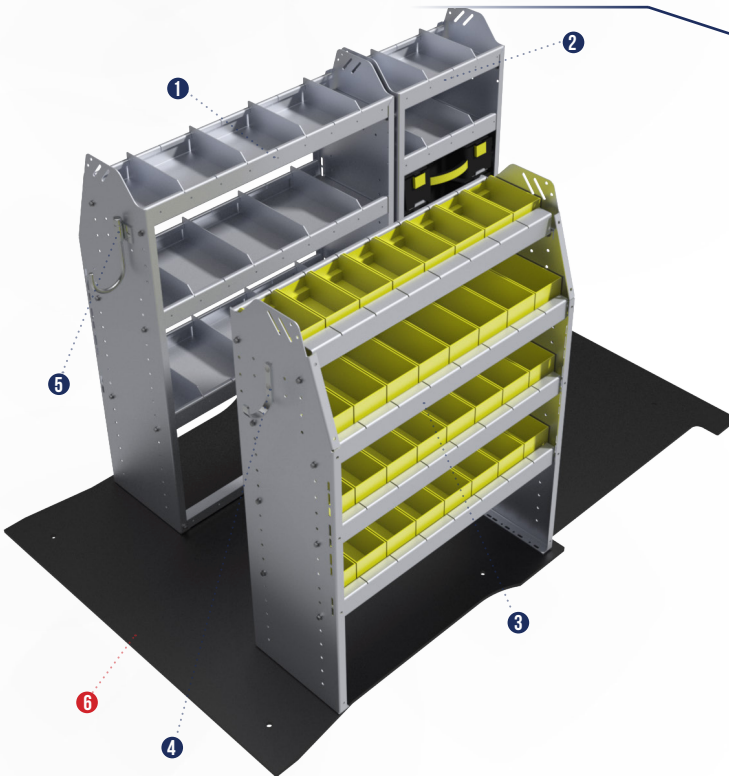

#	QTY	PART NUMBER	DESCRIPTION
1	1	21-3348-3	PROFILED BACK SHELF UNIT 36"WIDE X 13.5"DEEP X 48"HIGH WITH 3 SHELVES
2	1	15-1348-4	PROFILED BACK CARRY CASE CABINET 18-7/8"WIDE X 13.5"DEEP X 48"HIGH WITH 4 CARRYCASES
3	1	23-3348-4	PROFILED BACK BIN SHELF UNIT 34.5"WIDE X 13.5"DEEP X 48"HIGH WITH 4 SHELVES
4	1	30-HK-FMD	FIXED MEDIUM HOOK (3" OPENING)
5	1	30-HK-SMD	SWIVEL MEDIUM HOOK (4" OPENING)
OPTIONS			
6	1	31-FC20-XX	--OPTIONAL-- SEE VEHICLE SPECIFIC RIGID FLOORING SYSTEMS SECTION



163



5.1



YES

TRADE PACKAGES



TRANSIT CONNECT 120.5" WHEELBASE REGULAR ROOF

60-FC21-D1

DELIVERY PACKAGE

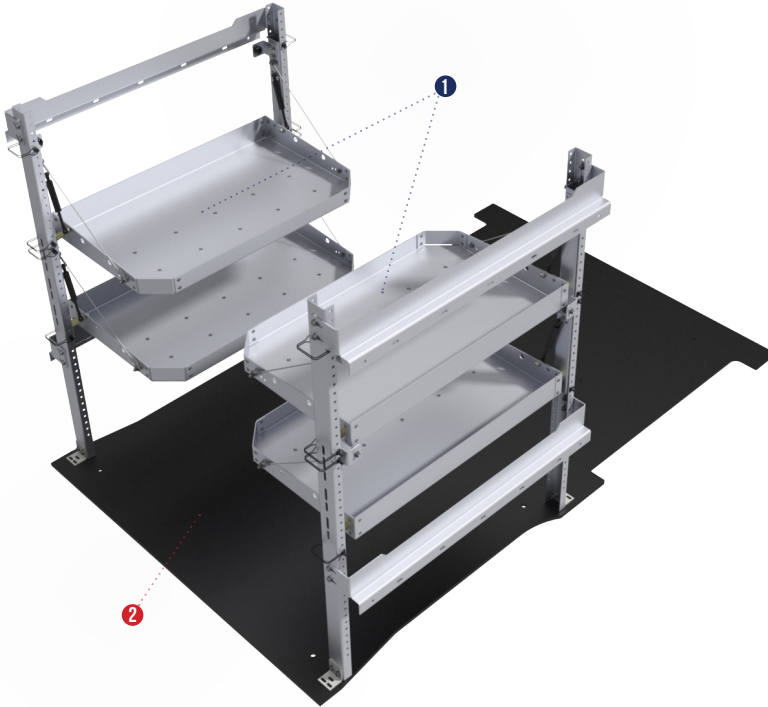

#	QTY	PART NUMBER	DESCRIPTION
1	2	26-3048-20	2 LEVEL FOLD-UP SHELVING UNIT, 35" WIDE X 18" DEEP X 48" HIGH
OPTIONS			
2	1	31-FC20-XX	--OPTIONAL-- SEE VEHICLE SPECIFIC RIGID FLOORING SYSTEMS SECTION

75

2.6

YES

RIGID FLOORING OPTIONS FOR FORD TRANSIT CONNECT 120.5" WB



ULTRAFLOOR

RIGID. 1/2" thick 100% recycled plastic composite. Extremely rigid floor is the most durable in its class. Long life, enduring extreme temperatures to avoid cracking and splitting. Non-porous surface is liquid resistant to eliminate bacteria and mold formation. Heavy-duty protection adds to end-of-lease resale value. For use under the harshest conditions including forklift loading.



ULTRAGRIP

ANTI-SLIP. Rigid 1/2" thick 100% rubber coated composite plastic. The most anti-slip rigid floor in its class. Non-porous surface is liquid resistant to eliminate bacteria and mold formation. Heavy-duty protection adds to end-of-lease resale value with added benefit of non-slip surface.



STABILIGRIP

STABLE. It is one of the only dimensional stable composite floors available on the market for cargo vehicles. It is engineered to endure all climates and temperatures without bulging or buckling. StabiliGrip is extremely durable, impact resilient, moisture resistant, rot proof, and anti-slip.

PART NUMBER	FLOOR MODEL	# PIECES	TOTAL LENGTH	TOTAL WIDTH	BETWEEN WHEELHOUSES	INSTALL (MIN.)	WEIGHT (LBS.)	OPTIONS	
								SIDE SILL	REAR SILL
31-FC20-11	ULTRAFLOOR	1	80.00 IN.	51.37 IN.	46.75 IN.	15	50	31-FC20-32	31-FC20-41
31-FC20-12	ULTRAFLOOR	2	80.00 IN.	51.37 IN.	46.75 IN.	15	50	31-FC20-32	31-FC20-41
31-FC20-21	ULTRAGRIP	1	80.00 IN.	51.37 IN.	46.75 IN.	15	56	31-FC20-32	31-FC20-41
31-FC20-22	ULTRAGRIP	2	80.00 IN.	51.37 IN.	46.75 IN.	15	56	31-FC20-32	31-FC20-41
31-FC20-01	STABILIGRIP	1	80.00 IN.	51.37 IN.	46.75 IN.	15	50	31-FC20-32	31-FC20-41
31-FC20-02	STABILIGRIP	2	80.00 IN.	51.37 IN.	46.75 IN.	15	50	31-FC20-32	31-FC20-41

TRADE PACKAGES

PARTITIONS

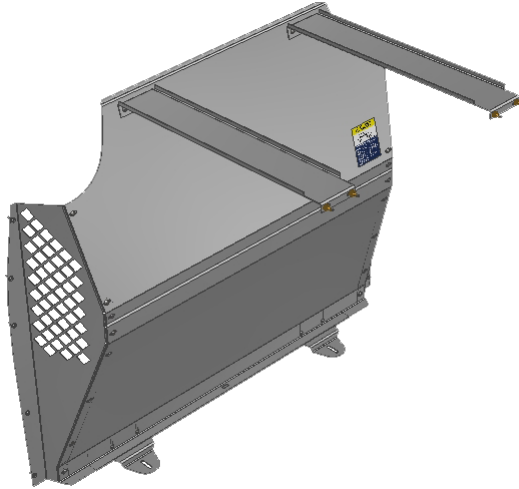

INSIDE ROOF HEIGHT
REGULAR ROOF: 46"

PART NUMBER	DESCRIPTION	FITS:	WEIGHT (LBS.)
10-FC01-121	PROFILED SOLID PARTITION	REGULAR ROOF	45

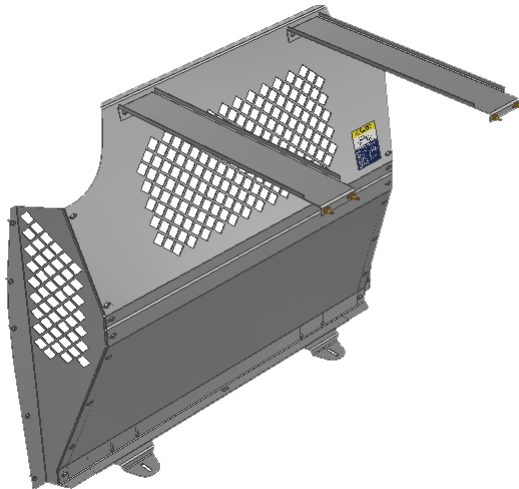

INSIDE ROOF HEIGHT
REGULAR ROOF: 46"

PART NUMBER	DESCRIPTION	FITS:	WEIGHT (LBS.)
10-FC01-122	PROFILED PERFORATED PARTITION	REGULAR ROOF	41

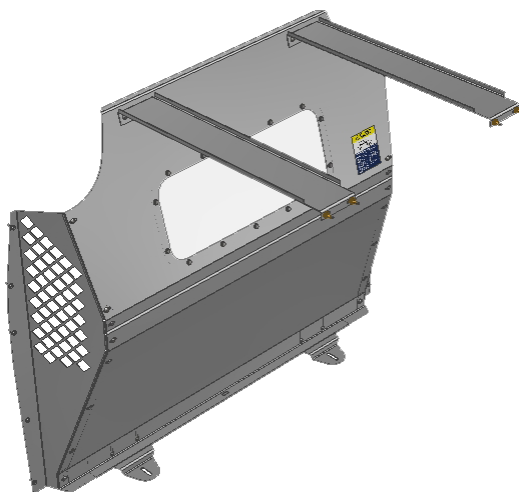

INSIDE ROOF HEIGHT
REGULAR ROOF: 46"

PART NUMBER	DESCRIPTION	FITS:	WEIGHT (LBS.)
10-FC01-123	PROFILED WINDOW PARTITION	REGULAR ROOF	43

TRADE PACKAGES

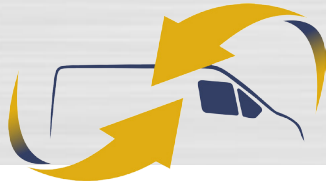

ACCESSORIES

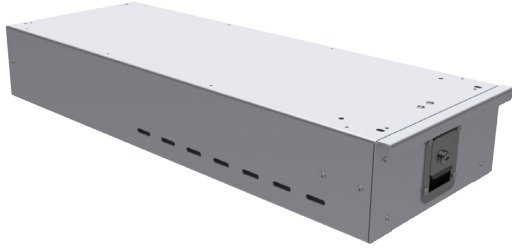

PART NUMBER	DESCRIPTION	DEEP (IN.)	WIDE (IN.)	HIGH (IN.)	DIVIDERS	WEIGHT (LBS.)
11-8320-0	DRAWER CABINET	36	13.5	6	4	24.2

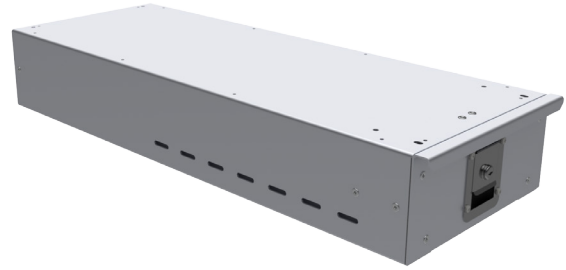

PART NUMBER	DESCRIPTION	DEEP (IN.)	WIDE (IN.)	HIGH (IN.)	DIVIDERS	WEIGHT (LBS.)
11-8420-0	DRAWER CABINET	48	13.5	6	5	30.5

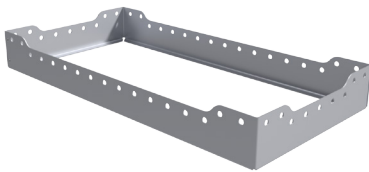

PART NUMBER	DESCRIPTION	DEEP (IN.)	WIDE (IN.)	HIGH (IN.)	FITS :	WEIGHT (LBS.)
30-TE-33	TOP EDGE	36	13.5	4.5	11-3306-0	4.35

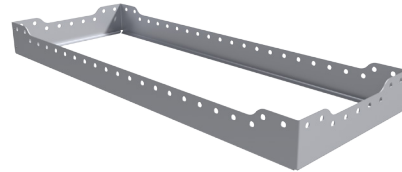

PART NUMBER	DESCRIPTION	DEEP (IN.)	WIDE (IN.)	HIGH (IN.)	FITS :	WEIGHT (LBS.)
30-TE-34	TOP EDGE	48	13.5	4.5	11-3406-0	4.79



PART NUMBER	DESCRIPTION	DEEP (IN.)	WIDE (IN.)	HIGH (IN.)	BOLT DOWN BRACKET	WEIGHT (LBS.)
11-8320-0	DRAWER CABINET	36	18	20	30-FH-3	58.74



PART NUMBER	DESCRIPTION	DEEP (IN.)	WIDE (IN.)	HIGH (IN.)	BOLT DOWN BRACKET	WEIGHT (LBS.)
11-8420-0	DRAWER CABINET	48	18	20	30-FH-8	72.77

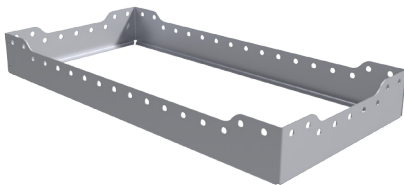

PART NUMBER	DESCRIPTION	DEEP (IN.)	WIDE (IN.)	HIGH (IN.)	FITS :	WEIGHT (LBS.)
30-TE-83	TOP EDGE	36	13.5	4.5	11-8320-0	5.34

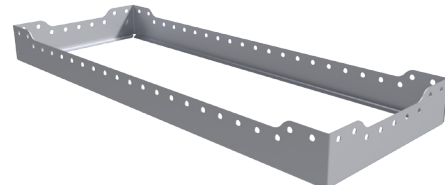

PART NUMBER	DESCRIPTION	DEEP (IN.)	WIDE (IN.)	HIGH (IN.)	FITS :	WEIGHT (LBS.)
30-TE-84	TOP EDGE	48	18	4.5	11-8420-0	5.78

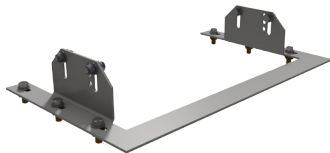

PART NUMBER	DESCRIPTION	FITS :	MATERIAL	WEIGHT (LBS.)
30-FH-3	DRAWER BOLT DOWN BRACKET	11-3306-0 AND 11-3406-0	GALV. STEEL	3



PART NUMBER	DESCRIPTION	FITS :	MATERIAL	WEIGHT (LBS.)
30-FH-8	DRAWER BOLT DOWN BRACKET	11-8320-0 AND 11-8420-0	GALV. STEEL	4

TRADE PACKAGES

ACCESSORIES



PART NUMBER	DESCRIPTION	OPENING RADIUS	DEEP (IN.)	WIDE (IN.)	HIGH (IN.)	WEIGHT (LBS.)
30-HK-CSM	SMALL COAT HOOK (ZINC)	0.625"	1.5"	0.61"	3.11"	0.133
30-HK-CMD	MEDIUM COAT HOOK (ZINC)	1.25"	1.7"	1.5"	2.03"	0.123

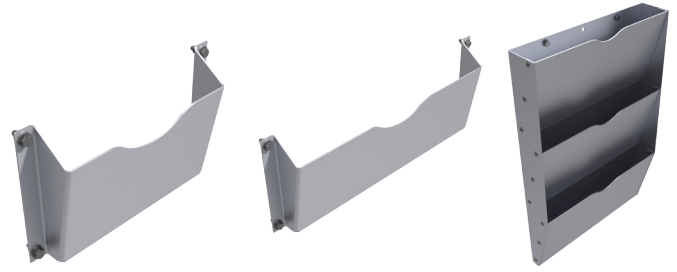

PART NUMBER	DESCRIPTION	DOCUMENT SIZE	DEEP (IN.)	WIDE (IN.)	HIGH (IN.)	WEIGHT (LBS.)
30-DH-LTR-1	SINGLE DOCUMENT HOLDER	LETTER	2.1"	11.5"	7"	0.8
30-DH-LGL-1	SINGLE DOCUMENT HOLDER	LEGAL	2.1"	18"	7"	0.9
30-DH-LGL-3	TRIPLE DOCUMENT HOLDER	LEGAL	3.25"	16"	24"	3.6



PART NUMBER	DESCRIPTION	OPENING RADIUS	DEEP (IN.)	WIDE (IN.)	HIGH (IN.)	WEIGHT (LBS.)
30-HK-FSM	FIXED SMALL HOOK	2"	2.0"	0.75"	4.75"	0.11
30-HK-FMD	FIXED MEDIUM HOOK	3"	3.0"	0.75"	5.25"	0.16
30-HK-FLG	FIXED LARGE HOOK	4"	4.0"	0.75"	5.75"	0.16



PART NUMBER	DESCRIPTION	OPENING RADIUS	DEEP (IN.)	WIDE (IN.)	HIGH (IN.)	WEIGHT (LBS.)
30-HK-SSM	SWIVEL SMALL HOOK	3"	3.86"	3"	7.75"	0.41
30-HK-SMD	SWIVEL MEDIUM HOOK	4"	4.86"	3"	8.25"	0.44
30-HK-SLG	SWIVEL LARGE HOOK	5"	5.86"	5"	8.75"	0.47

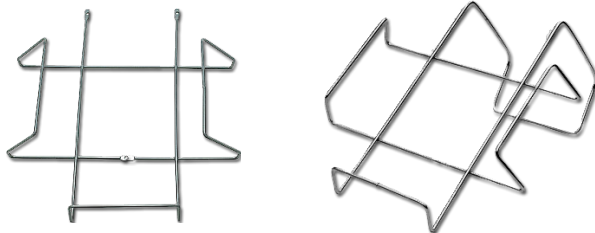

PART NUMBER	DESCRIPTION	MATERIAL	DEEP (IN.)	WIDE (IN.)	HIGH (IN.)	WEIGHT (LBS.)
30-HH-WM	WALL MOUNTED HARD HAT HOLDER	STEEL	11.750"	12.250"	3.250"	0.437
30-HH-HR	HEAD REST MOUNT HARD HAT HOLDER	STEEL	11.750"	12.250"	3.250"	0.491

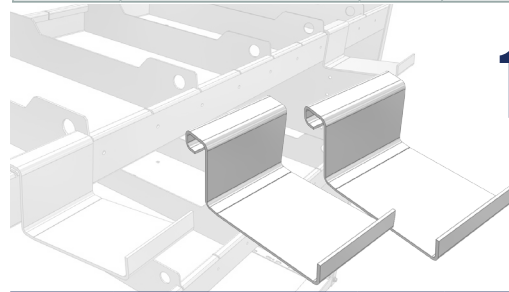

1 PAIR

PART NUMBER	DESCRIPTION	MATERIAL	DEEP (IN.)	WIDE (IN.)	HIGH (IN.)	WEIGHT (LBS.)
30-HK-MSL	MOVABLE STEP LADDER SHELF HOOKS	ALUM (125)	6.750"	4.000"	3.125"	1.36



PART NUMBER	DESCRIPTION	DEEP (IN.)	WIDE (IN.)	HIGH (IN.)	WEIGHT (LBS.)
30-CH-12	SPRAY CAN HOLDER W/POCKET	4.00"	9.94"	8.82"	1.36



PART NUMBER	DESCRIPTION	DEEP (IN.)	WIDE (IN.)	HIGH (IN.)	WEIGHT (LBS.)
30-CH-23	CAULKING TUBE HOLDER	3.5"	9.94"	8.82"	1.36

TRADE PACKAGES



ACCESSORIES

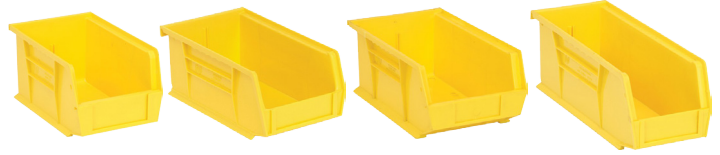

PART NUMBER	DESCRIPTION	MATERIAL	DEEP (IN.)	WIDE (IN.)	HIGH (IN.)	WEIGHT (LBS.)
30-HS-07	HITCH MOUNTED STEP	ALUMINUM	7"	18"	2.5"	6.3

PART NUMBER	DESCRIPTION	DEEP (IN.)	WIDE (IN.)	HIGH (IN.)	WEIGHT (LBS.)	COLOUR
SH-BIN	SHORT STORAGE BIN	7.375"	4.125"	3.000"	0.20	YELLOW
SM-BIN	SMALL STORAGE BIN	9.250"	6.000"	5.000"	0.63	YELLOW
MD-BIN	MEDIUM STORAGE BIN	10.875"	4.125"	4.000"	0.48	YELLOW
LG-BIN	LARGE STORAGE BIN	13.625"	8.500"	6.000"	1.33	YELLOW



PART NUMBER	DESCRIPTION	DIAMETER (IN.)	HIGH (IN.)	COLOUR	BASE	WEIGHT (LBS.)
30-FLT-BLK	FLETTNER TCX-2 VENTILATOR	10.2"	6.54"	BLACK	STD	1.84
30-FLT-WHT	FLETTNER TCX-2 VENTILATOR	10.2"	6.54"	WHITE	STD	1.84
30-FLT-BLK-NW	FLETTNER TCX-2 VENTILATOR	3.9"	6.0"	BLACK	NRW	1.84
30-FLT-EXT	FLETTNER TCX-2 VENT. EXTENSION	3.9"	6.0"	BLACK	STD	0.45

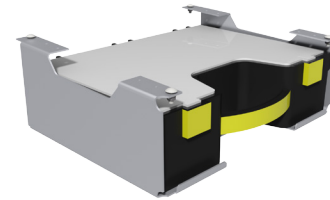

PART NUMBER	DESCRIPTION	CARRYCASE INCLUDED	DEEP (IN.)	WIDE (IN.)	HIGH (IN.)	WEIGHT (LBS.)
30-CCH-SK	UNDER SHELF CARRYCASE HOLDER	YES	13.750"	16.810"	6.000"	3.44



PART NUMBER	DESCRIPTION	COMPARTMENTS	DEEP (IN.)	WIDE (IN.)	HIGH (IN.)	WEIGHT (LBS.)
30-CCO-10	CARRYCASE ORGANIZER	10	13.500"	16.750"	4.250"	4.85

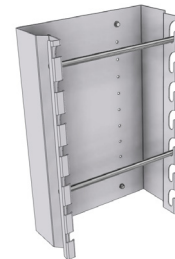

PART NUMBER	DESCRIPTION	REEL GUIDES	DEEP (IN.)	WIDE (IN.)	HIGH (IN.)	WEIGHT (LBS.)
30-CRH-24	CABLE REEL HOLDER	2	7.00"	15.50"	24.00"	8.04

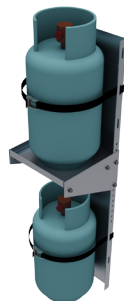

PART NUMBER	DESCRIPTION	DEEP (IN.)	WIDE (IN.)	HIGH (IN.)	WEIGHT (LBS.)	CAM BUCKLES
30-TBH	TWIN BOTTLE HOLDER	11.10"	11.00"	44.00"	8.74	2X 48" STRAP



PART NUMBER	DESCRIPTION	MATERIAL	DEEP (IN.)	WIDE (IN.)	HIGH (IN.)	WEIGHT (LBS.)
30-BH-SM	BOTTLE HOLDER (SMALL) 1X 48" STRAP	ALUM.	0.96"	6.000"	12.00"	1.01
30-BH-LG	BOTTLE HOLDER (LARGE) 2X 48" STRAP	ALUM.	0.96"	6.750"	24.00"	1.50

TRADE PACKAGES

ACCESSORIES



PART NUMBER	DESCRIPTION	DEEP (IN.)	WIDE (IN.)	HIGH (IN.)	MATERIAL	WEIGHT (LBS.)
108539	FIRST-AID KIT	8.25	5.25	2.75	PLASTIC	0.85
30-FAH-1	BRACKET FOR FIRST-AID KIT	36	13.5	6	ALUMINUM	2.42



PART NUMBER	DESCRIPTION	UNIT	MATERIAL
460-301	SERIES L LOGISTIC TRACK	100"	ALUMINUM
454-301	SERIES L STUD FITTING WITH RING	EA.	STEEL AND ALUMINUM



PART NUMBER	DESCRIPTION	LENGTH	WIDTH	MATERIAL	WEIGHT (LBS.)
30-CBS-24	STRAP WITH CAMBUCKLE	24	1	NYLON	.23
30-CBS-36	STRAP WITH CAMBUCKLE	36	1	NYLON	.33
30-CBS-48	STRAP WITH CAMBUCKLE	48	1	NYLON	.40
30-CBS-72	STRAP WITH CAMBUCKLE	72	1	NYLON	.45



PART NUMBER	DESCRIPTION	CAPACITY	TYPE	PSI	MOUNT TYPE	WEIGHT (LBS.)
SAQ814	FIRE EXTINGUISHER	2.5LBS	ABC	150	VEHICLE	4.25
SC946	FIRE EXTINGUISHER	5LBS	ABC	195	VEHICLE	10.5



PART NUMBER	DESCRIPTION	DIAMETER	LUMENS	VOLTAGE	LENS
701-041	LED DOME LAMP	6.125	648	12 VDC	CLEAR



PART NUMBER	DESCRIPTION	BEAN	VOLTS	WATTS	LUMENS
709-713	LED WORK LAMP	FLOOD	10-30 VDC	42	3360



1 PAIR

PART NUMBER	DESCRIPTION	DEEP (IN.)	WIDE (IN.)	HIGH (IN.)	WEIGHT (LBS.)	COLOUR
30-QFC-01	QUICK FIST CLAMP	2.875"	0.750"	2.500"	0.31	BLACK



PART NUMBER	DESCRIPTION	DEEP (IN.)	WIDE (IN.)	HIGH (IN.)	WEIGHT (LBS.)	COLOUR
30-HDL-PL	GRAB HANDLE	9.250"	6.000"	5.000"	0.63	BLACK



PART NUMBER	DESCRIPTION	SIZE (IN.)	HIGH (IN.)	AMPS	VOLTAGE
102177	LOW PROFILE LED MINIBAR	16.5" X 8.25"	3.625"	3	12-24VDC
110599	LED ROTATOR BEACON	7" DIAM.	5.25	1.3	12-24VDC



PART NUMBER	DESCRIPTION	DEEP	WIDE	HIGH	MATERIAL	WEIGHT (LBS.)
71422	3-TRIANGLE FLARE KIT	18.5"	5"	5"	PLASTIC	15.55
30-FKH-1	BRACKET (FLARE KIT)	36	13.5	6	ALUMINUM	24.2

TRADE PACKAGES



LADDER AND STEP LADDER RACKS

CONTRACTOR - PLUMBER - ELECTRICIAN

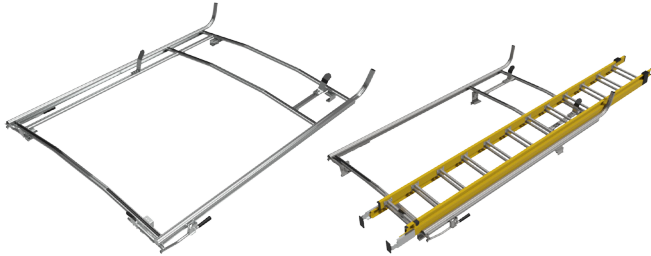

HVAC



PART NUMBER	RECOMMENDED TRADE	DRIVER SIDE		PASSENGER SIDE			WEIGHT (LBS.)	INSTALL	OPTIONS			
									4" TUBE	6" TUBE	2ND STEPLADDER OPTION (4'-6')	
CALL	CONTRACTOR/PLUMBER/ELECTRICIAN		8'-10'	FIXED	FIXED	MAX 28'		65	2H00	T4	T6	N/A
US	CONTRACTOR/PLUMBER/ELECTRICIAN		6'-8'	DROP	DROP	MAX 28'		115	2H00	N/A	N/A	N/A
TO	HVAC		6'-8'	FIXED	FIXED	MAX 28'		65	2H00	N/A	N/A	SL2
CONFIGURE	HVAC		6'-8'	FIXED	DROP	MAX 28'		115	2H00	N/A	N/A	SL2

CONTRACTOR - PLUMBER - ELECTRICIAN

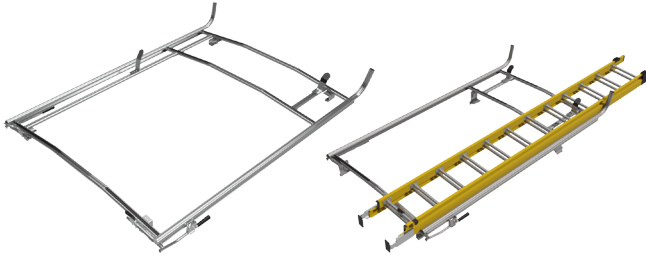

HVAC

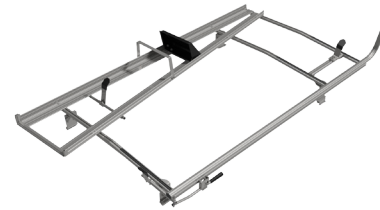

PART NUMBER	RECOMMENDED TRADE	DRIVER SIDE		PASSENGER SIDE			WEIGHT (LBS.)	INSTALL	OPTIONS			
									4" TUBE	6" TUBE	2ND STEPLADDER OPTION (4'-6')	
CALL	CONTRACTOR/PLUMBER/ELECTRICIAN		6'-8'	DROP	DROP	MAX 28'		115	2H00	N/A	N/A	N/A
US	HVAC		6'-8'	FIXED	DROP	MAX 28'		115	2H00	N/A	N/A	SL2

CONTRACTOR - PLUMBER - ELECTRICIAN



HVAC

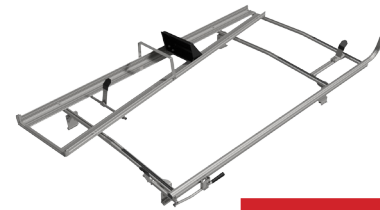

PART NUMBER	RECOMMENDED TRADE	DRIVER SIDE		PASSENGER SIDE			WEIGHT (LBS.)	INSTALL	OPTIONS			
									4" TUBE	6" TUBE	2ND STEPLADDER OPTION (4'-6')	
CALL	CONTRACTOR/PLUMBER/ELECTRICIAN		6'-8'	DROP	DROP	MAX 28'		115	2H00	N/A	N/A	N/A
US	HVAC		6'-8'	FIXED	DROP	MAX 28'		115	2H00	N/A	N/A	SL2
TO	CONTRACTOR/PLUMBER/ELECTRICIAN		6'-8'	DROP	DROP	MAX 28'		115	2H00	N/A	N/A	N/A
CONFIGURE	HVAC		6'-8'	FIXED	DROP	MAX 28'		115	2H00	N/A	N/A	SL2



YOUR DEALER:

DEALERS@GWAKITS.COM

G.W. ANGLIN MANUFACTURING INC.

**CUSTOMER SERVICE:
1.888.GWA.KITS (492-5487)
CS@GWAKITS.COM**

**WWW.GWAKITS.COM
INFO@GWAKITS.COM**